

SPEEDSTROKE GYM - Kayak

SPEEDSTROKE GYM - Canoe

KAYAKPRO *Shanghai InfoSports Co., Ltd.*

Rope/Bungee and Paddle Assembly Instructions



WHAT YOU WILL NEED BEFORE BEGINNING

- * 2 sets of ropes (the other 2 ropes in the package are spares– as is the additional bungee)
- * 3 pieces of the paddle shaft
- * The smallest Allen wrench in the set provided.

The following instructions from this point forward, assume the internal bungee arrangement is in place within the body of the SpeedStroke at arrival. If this is not the case please do not hesitate to contact us in order that we can assist further.

PRE-INSTRUCTION:

Once the main structure of the SpeedStroke is assembled, it should remain "upright." Do not place the machine on its side or upside down during final assembly.

INSTRUCTIONS:

1. On one side of the Speedstroke, run the bungee cord around the roller on the back of the machine, under the seat. See image below. It should go from the top of the roller to the bottom. PLEASE NOTE: You may need to remove the aluminium anti-twist connector to fit the bungee around the roller. If so, use the smallest Allen wrench in the kit provided. Loosen the screw to remove the anti-twist unit from the bungee, run bungee around roller (again, from top to bottom), and then reattach anti-twist unit by tightening recessed screw fully. See image below- (Black represents Rope- Hatched represents Bungee).

2. Repeat on the other side.

3. On one side of the SpeedStroke, attach the rope to the anti-twist unit. Use the smallest Allen wrench provided to tighten the screw fully around the rope. When you are done, the rope should be attached to the bungee by the anti-twist connector.

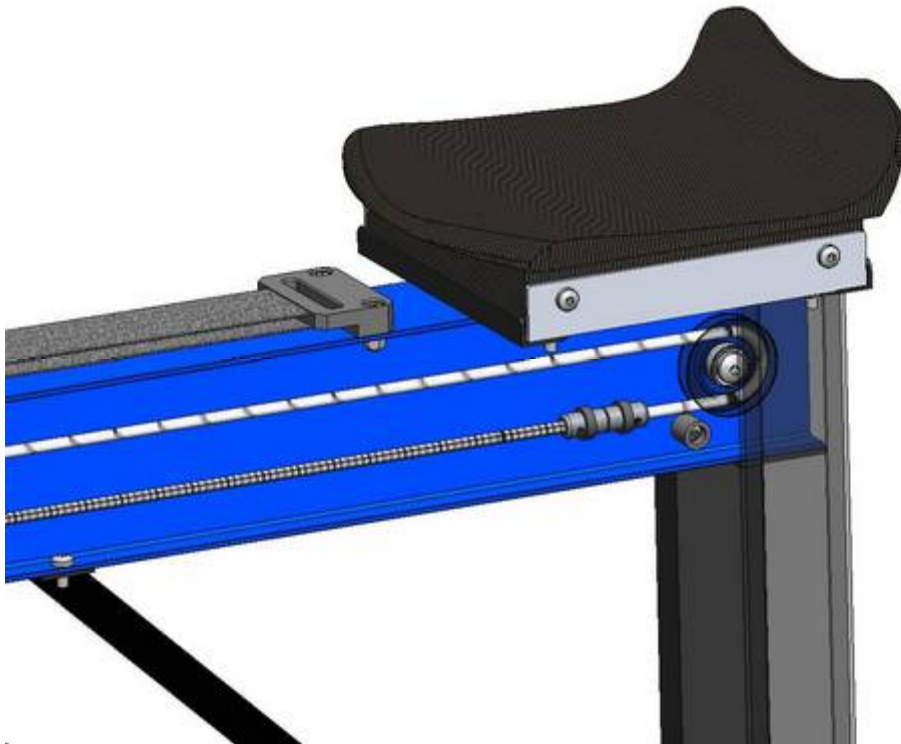

4. Repeat on the other side.

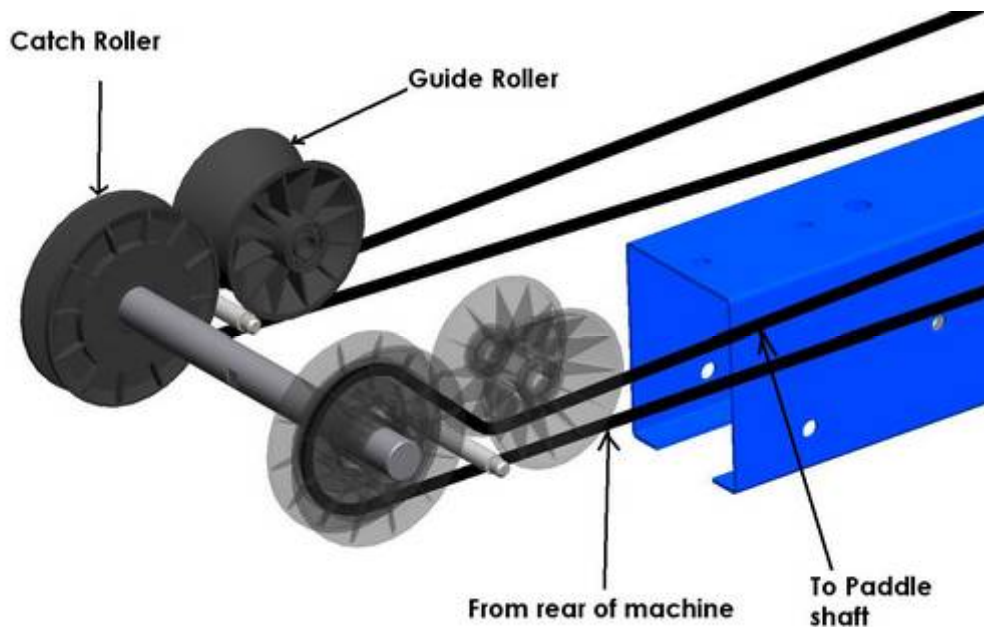

5. On one side of the SpeedStroke, run the rope around the rollers at the front of the machine, near the Flywheel. Do this as pictured in the image above. The rope travels around the bottom of the front catch roller, exits the top of that roller, and then (under) the bottom of the guide roller. The rope should exit toward the back of the machine (where the seat is), where, for now, you will leave it loose on the floor.

6. Repeat on the other side.

7. You will now assemble the paddle shaft (3 pieces). The piece without the ferrule installs in the middle. The other two pieces install on the outside with the screw pointed outward. For now, place the paddle shaft in its narrowest position, so it is as short as possible.

8. Unscrew the tip (insert) of the shaft on one side and remove the insert. Run the rope on that side through the hole in insert. Tie a knot in the rope on the "inside" of the tip, leaving about 10 cm of loose rope for placement inside the shaft. (It does not have to be exactly 10 cm, but you should measure from the knot to the end – you will need to match this on the other side.) Screw the tip (insert) back in the shaft, with the loose rope on the inside of the shaft. The rope should now be attached to that side of the shaft.

You can adjust the length of rope here.

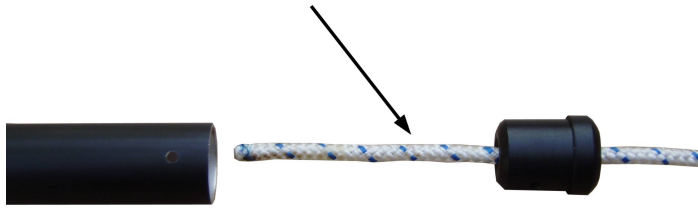

9. Repeat on the other side.

10. Once the paddle shaft is attached on both sides, use the two ferrules to adjust the length of the shaft to your own personal preference. Make sure the distance from the ferrules to the end of the shaft is uniform on both sides. Adjusting the length of the shaft will alter the paddling resistance; the longer the shaft, the greater the resistance, the shorter the shaft, the less the resistance.

11. The shaft-length adjustment will also allow you to customize Speedstroke to replicate precisely the paddling “feel” of your own boat.

12. Do not extend the shaft length past the “maximum length” markings.

Internal Bungee arrangement below:



13. Once the SpeedStroke is fully connected, in order to minimize the rope sway and to improve the positive action of SpeedStroke, adjust the bungee tensioner backward – (See image below) toward the paddler, there is an adjustment rope available which allows you to extend backward and locate the movable tension roller.

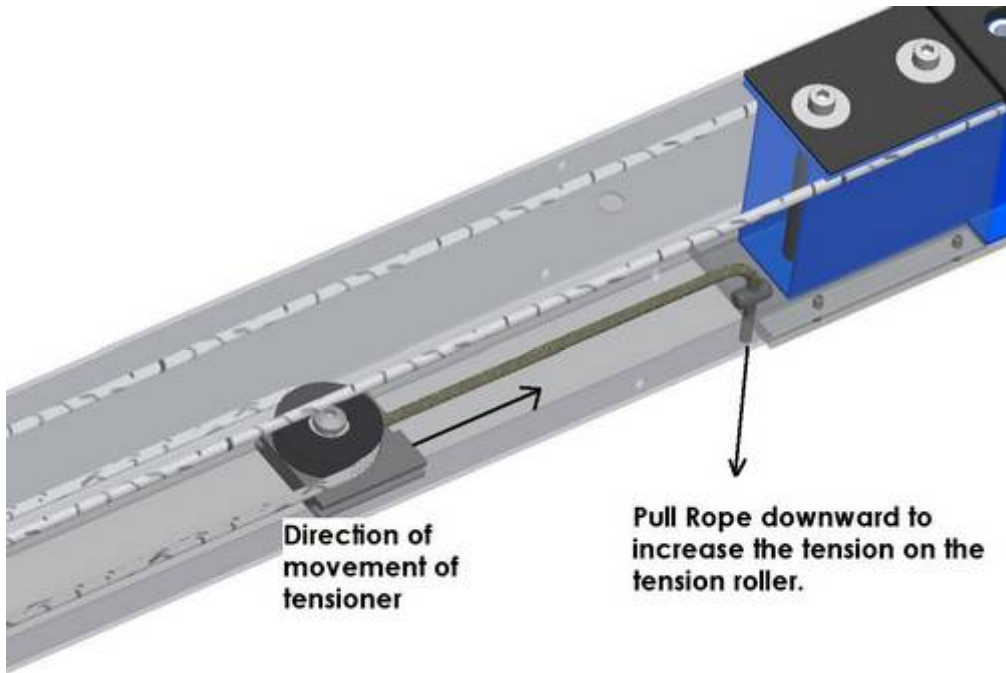

KAYAKPRO

Shanghai InfoSports Co., Ltd.



KayakPro USA LLC supplier of
Kayak Ergometers to the
2004 Athens Olympic Games



KayakPro USA LLC supplier of
Kayak Ergometers to the
2008 Beijing Olympic Games