



ASSEMBLY MANUAL

v2.0



SAFETY PRECAUTIONS

SAFE OPERATION AND USE

SERIOUS INJURY CAN OCCUR IF THE FOLLOWING PRECAUTIONS ARE NOT OBSERVED.

1. Always consult your physician prior to undertaking any exercise regimen.
2. Keep head, limbs, fingers, and hair clear of all moving parts and flywheel cage.
PLEASE NOTE For the KPC Ergometer, the largest working area is:
CLOSED FOR STORAGE 1.4M (L) X 0.6M (H) X 0.4M (W)
4' 7 1/2" (L) X 1' 11" (H) X 1' 4" (W)
OPENED OUT FOR USE 2.5M (L) X 0.6M (H) X 0.4M (W)
8' 3" (L) X 1' 11" (H) X 1' 4" (W)
SAFE WORKING AREA 3M (L) X 1.8M (H) X 1.75M (W)
9' 11" (L) X 5' 9" (H) X 5' 11" (W)
3. Inspect machine prior to use. Do not use the machine if it appears damaged or inoperable.
4. Contact manufacturer if machine is broken or jammed.
5. Use machine only as intended.
6. Do not modify the machine.
7. Children must not be allowed near this machine.
8. Teenagers must be supervised in the use of this machine.
9. By using the KPC Ergometer the user accepts all and full responsibility for self.

1

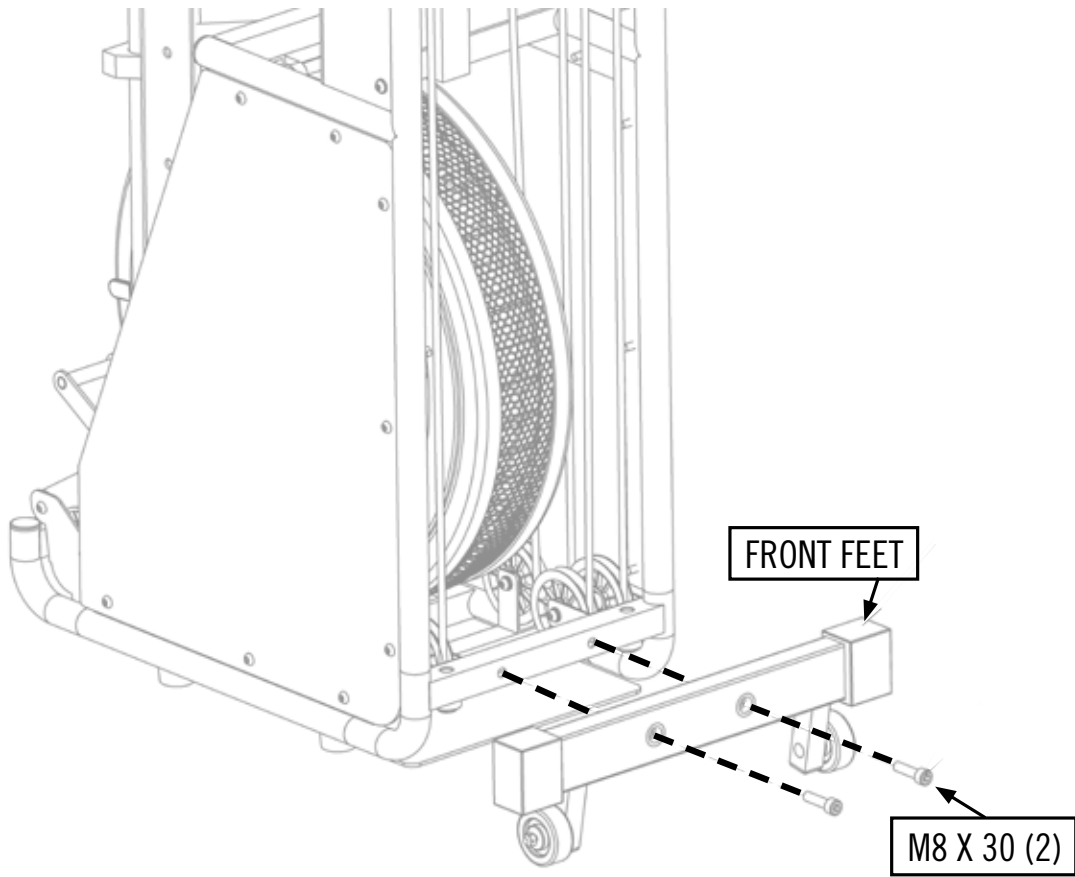

2

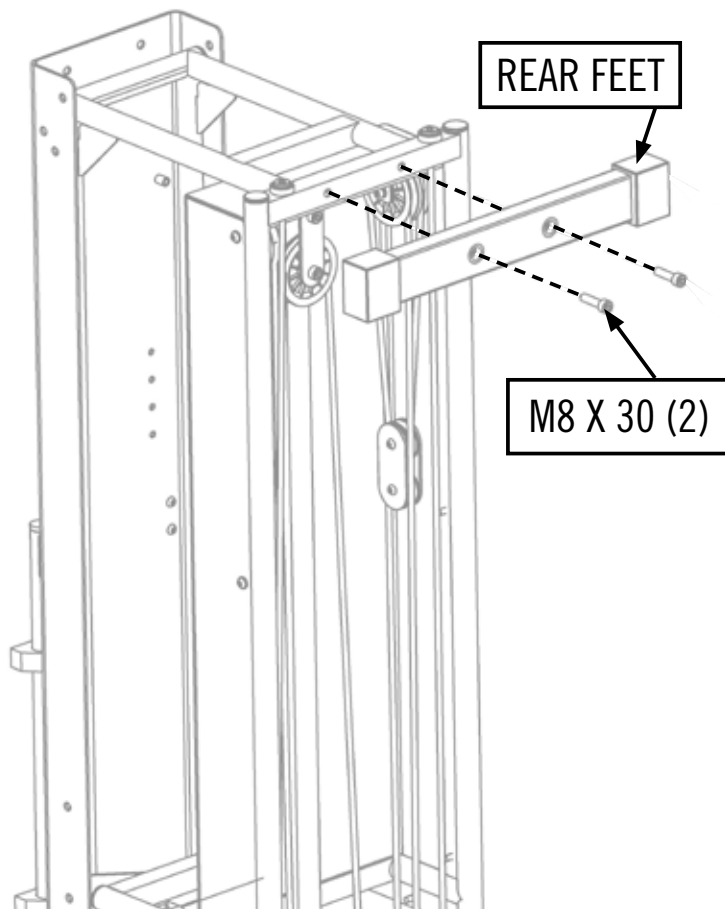

3

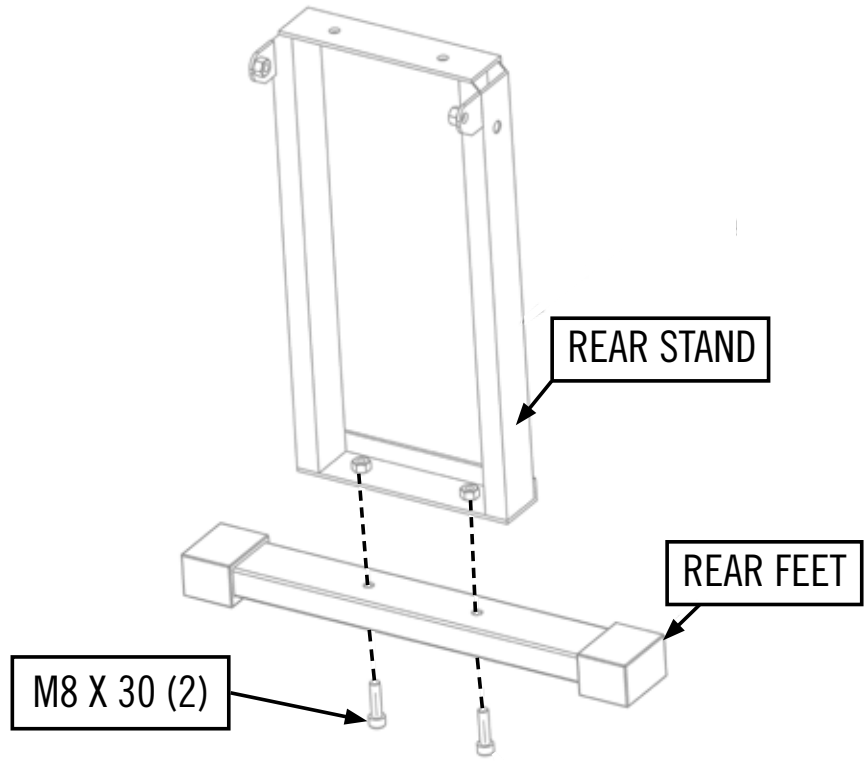

4

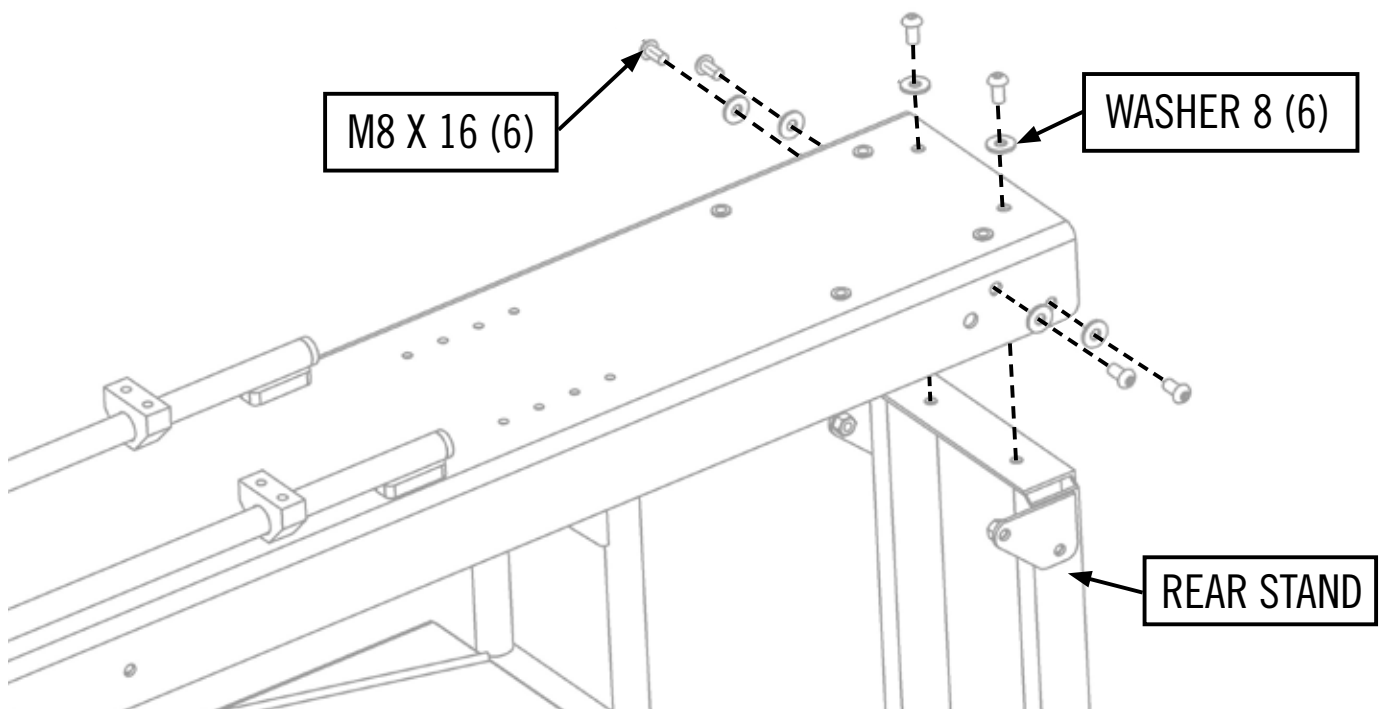

5

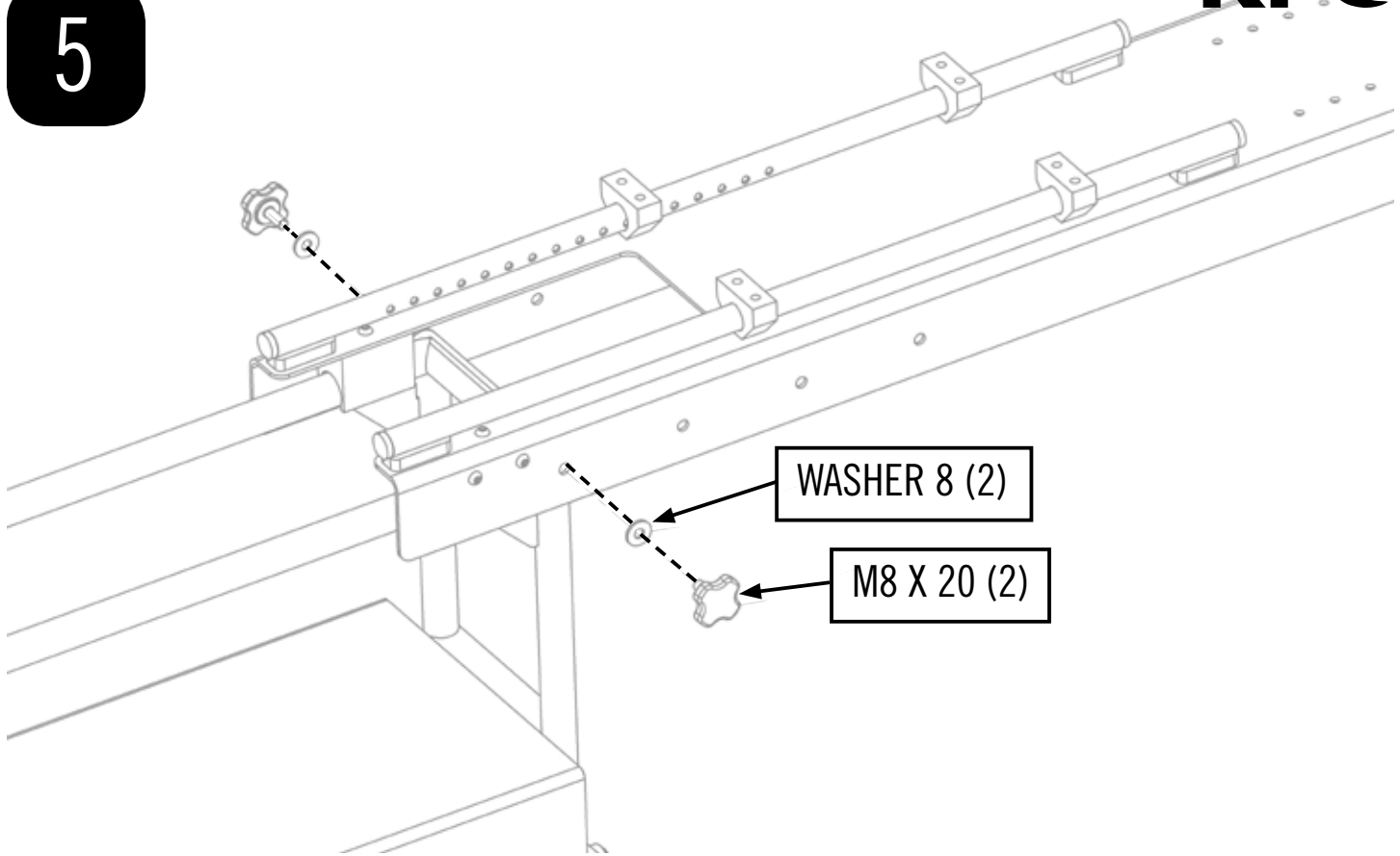

6

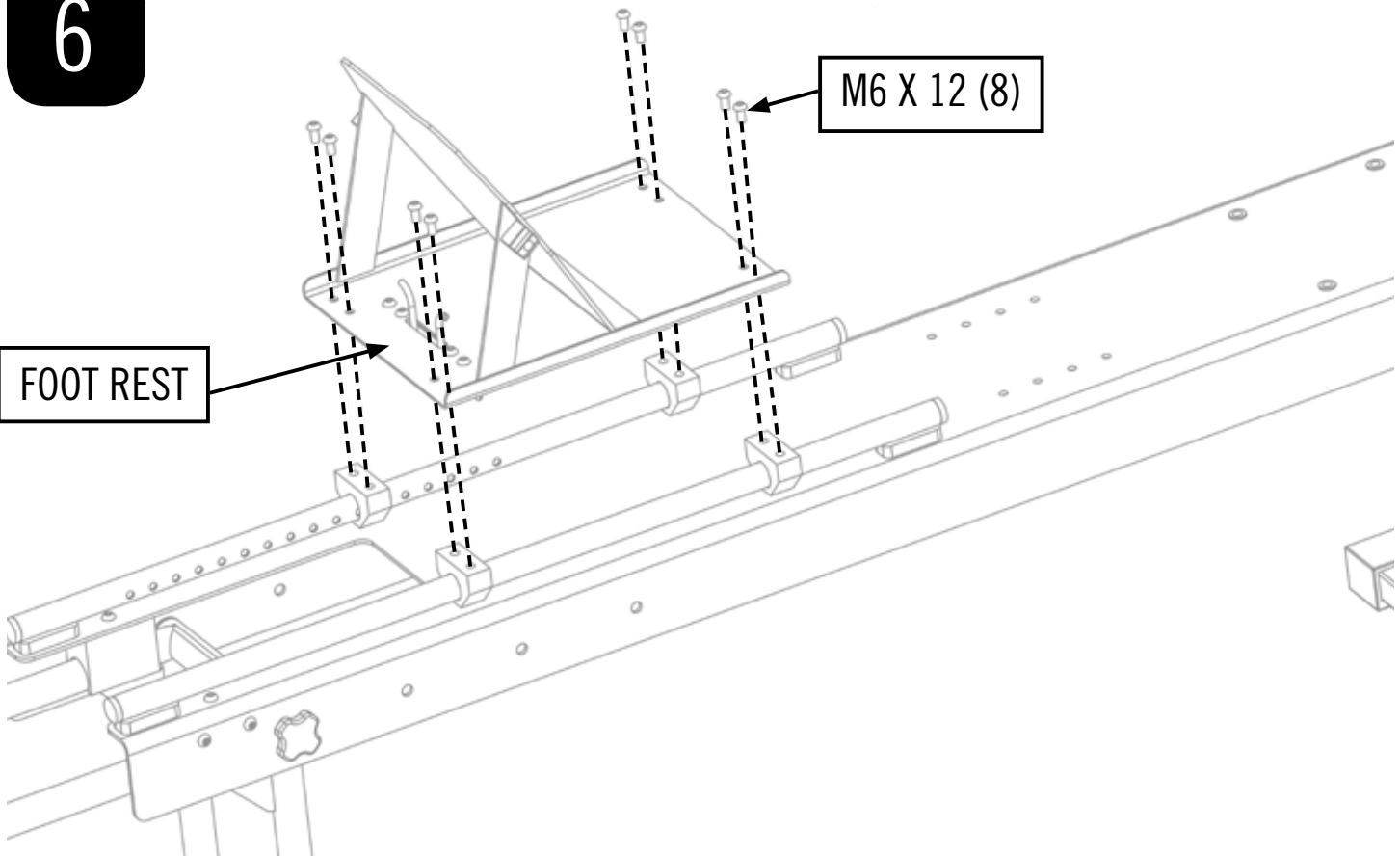

7

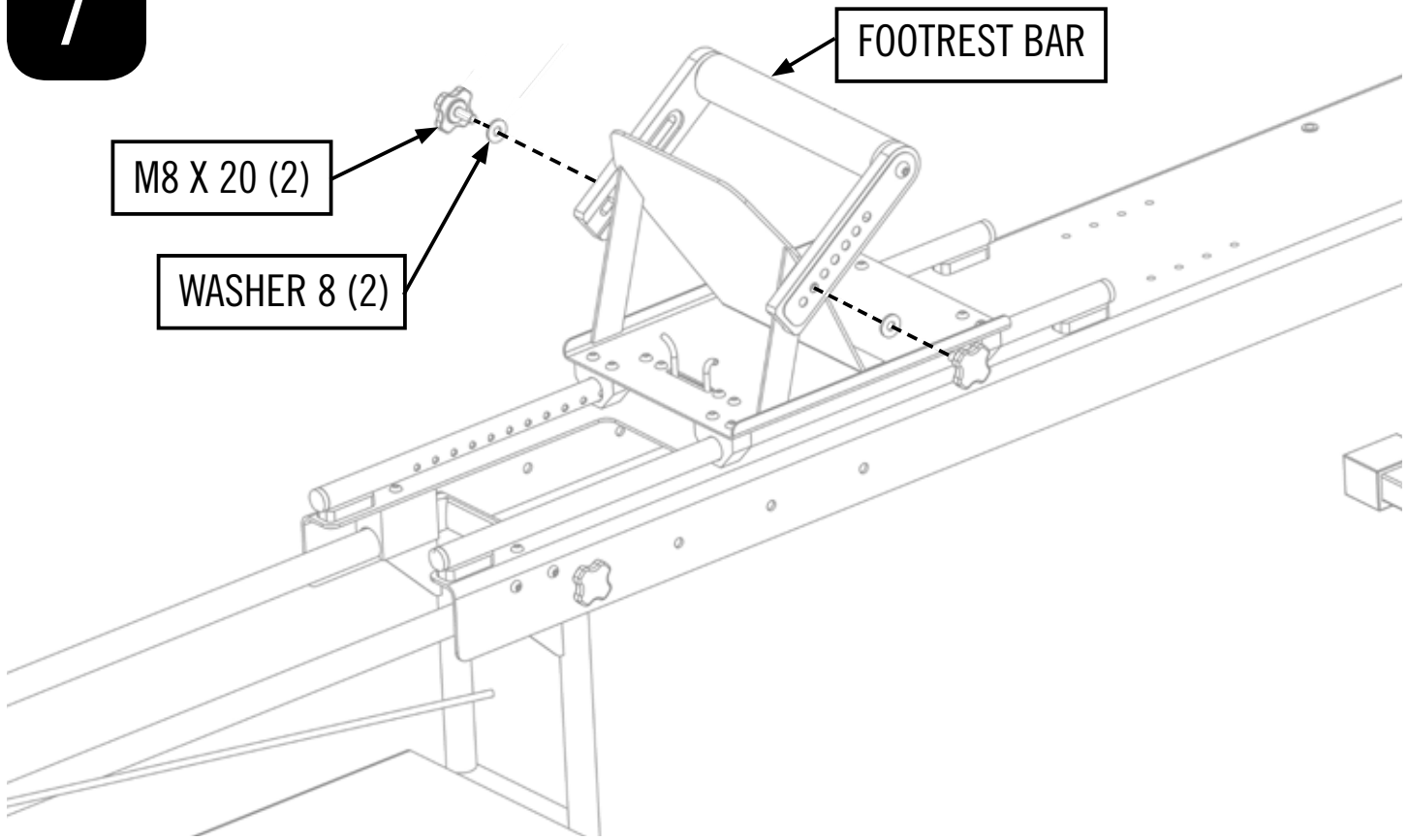

8

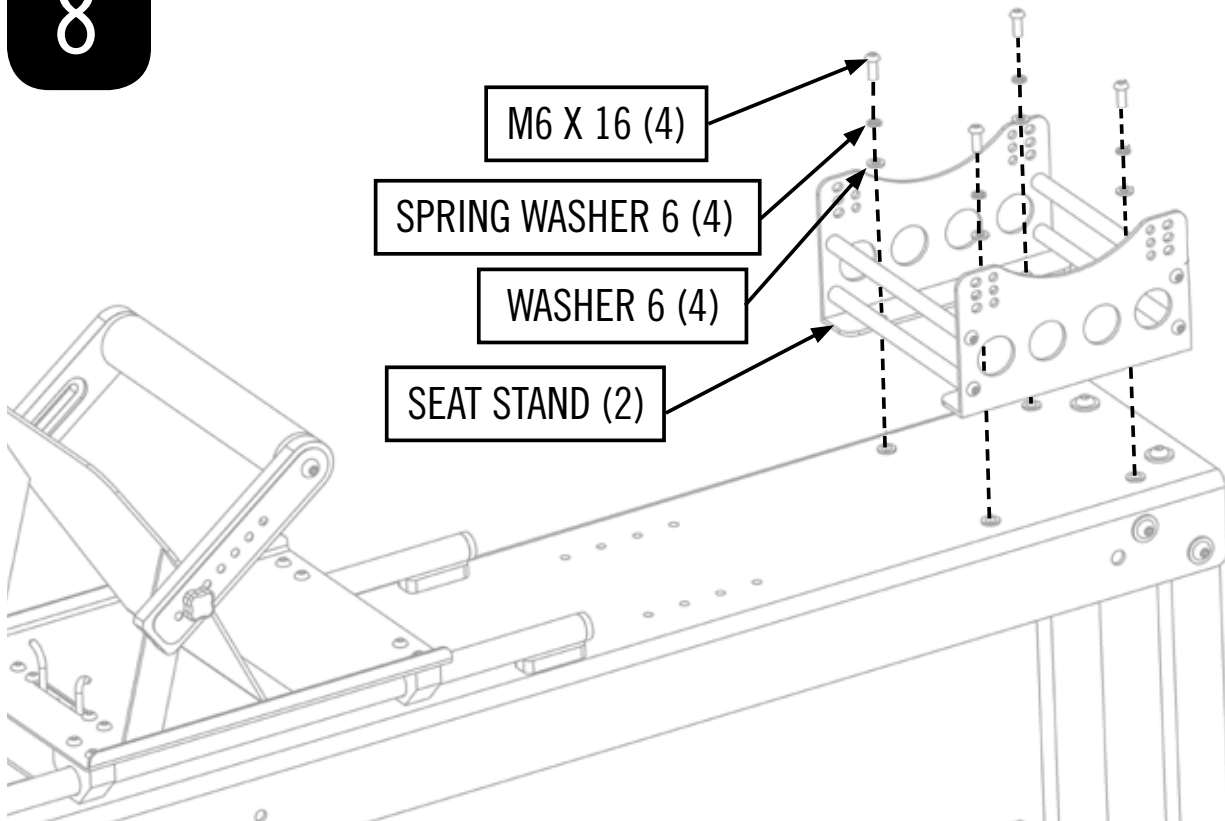

9

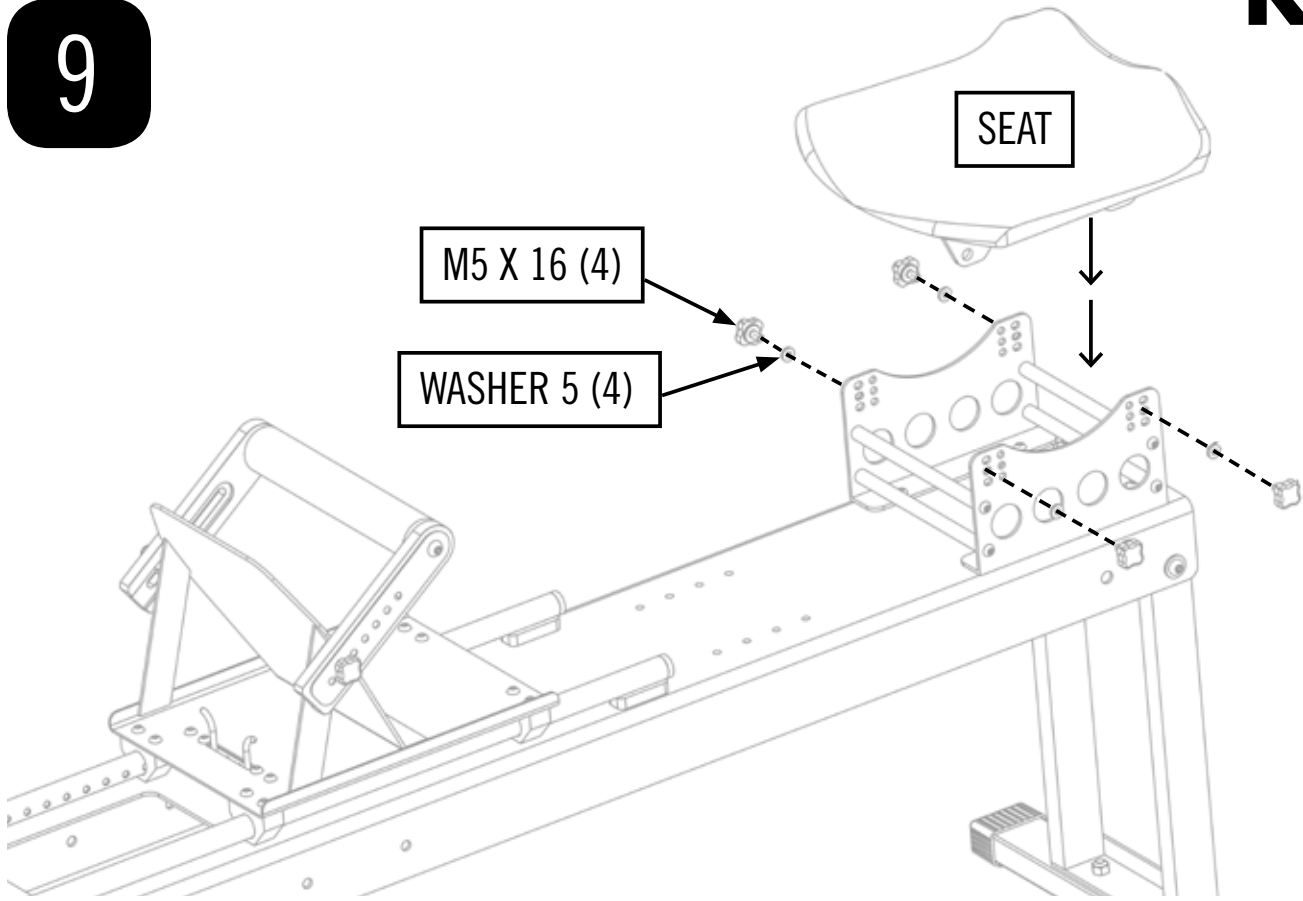

10

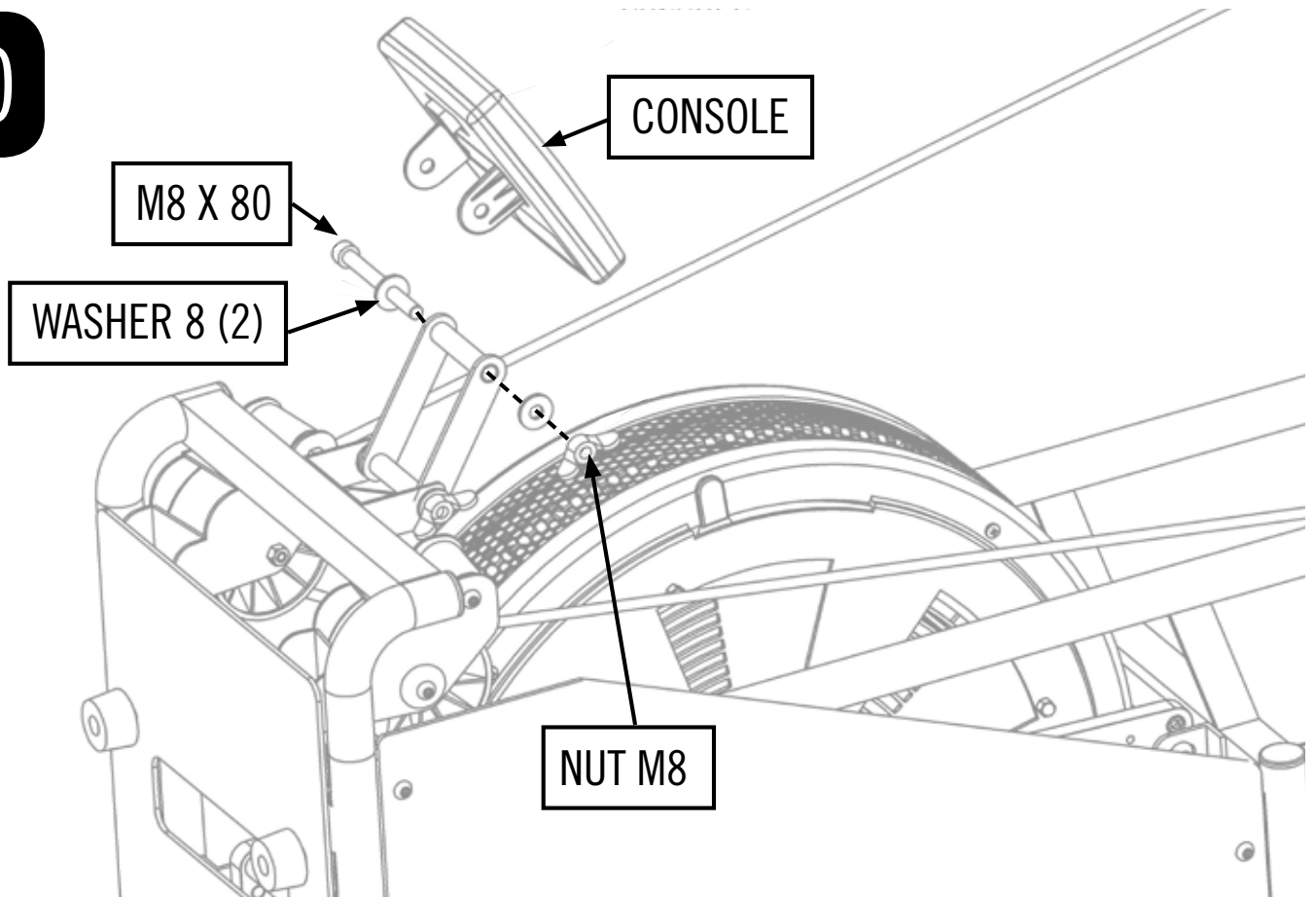

ROPE

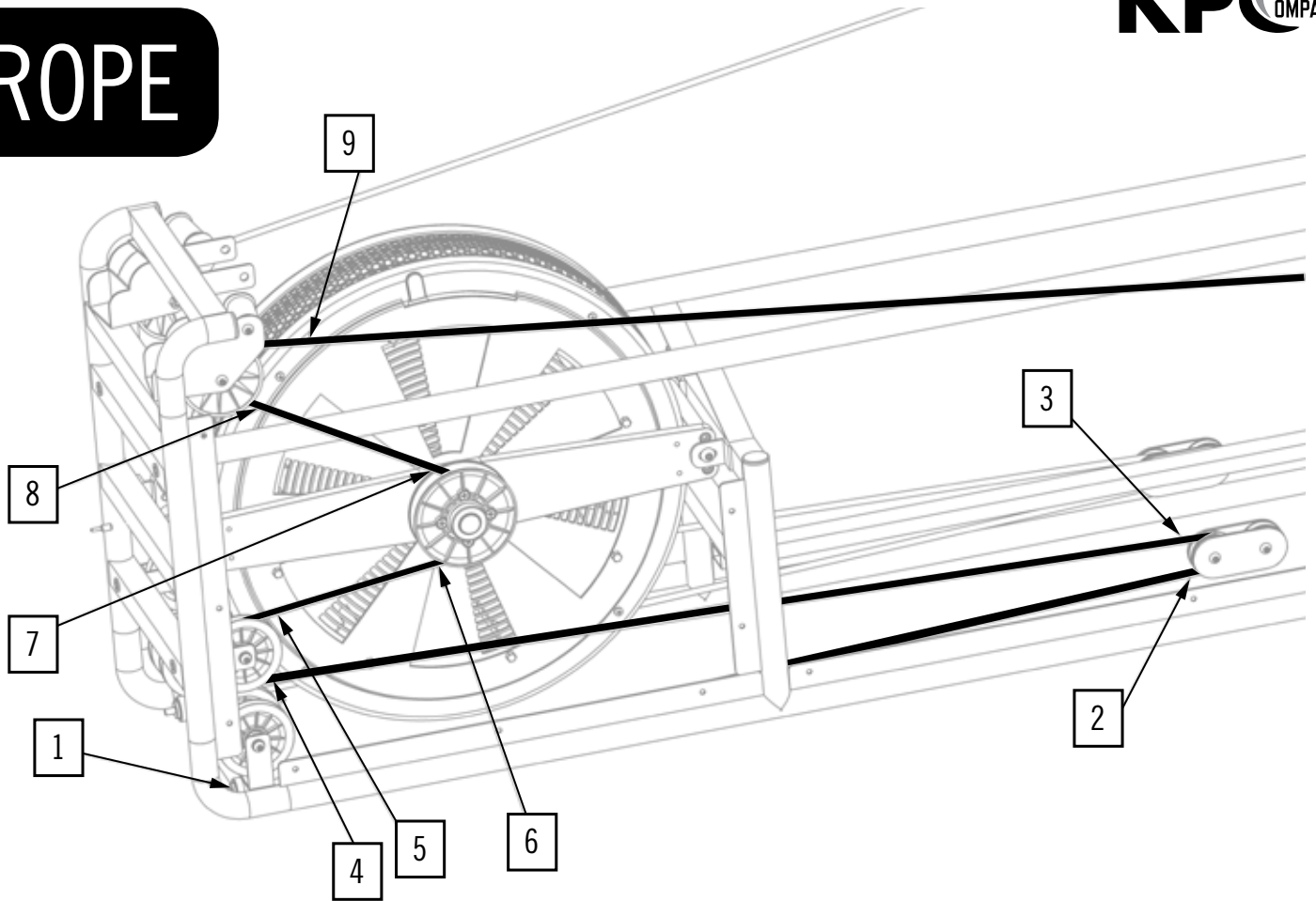

ELASTIC

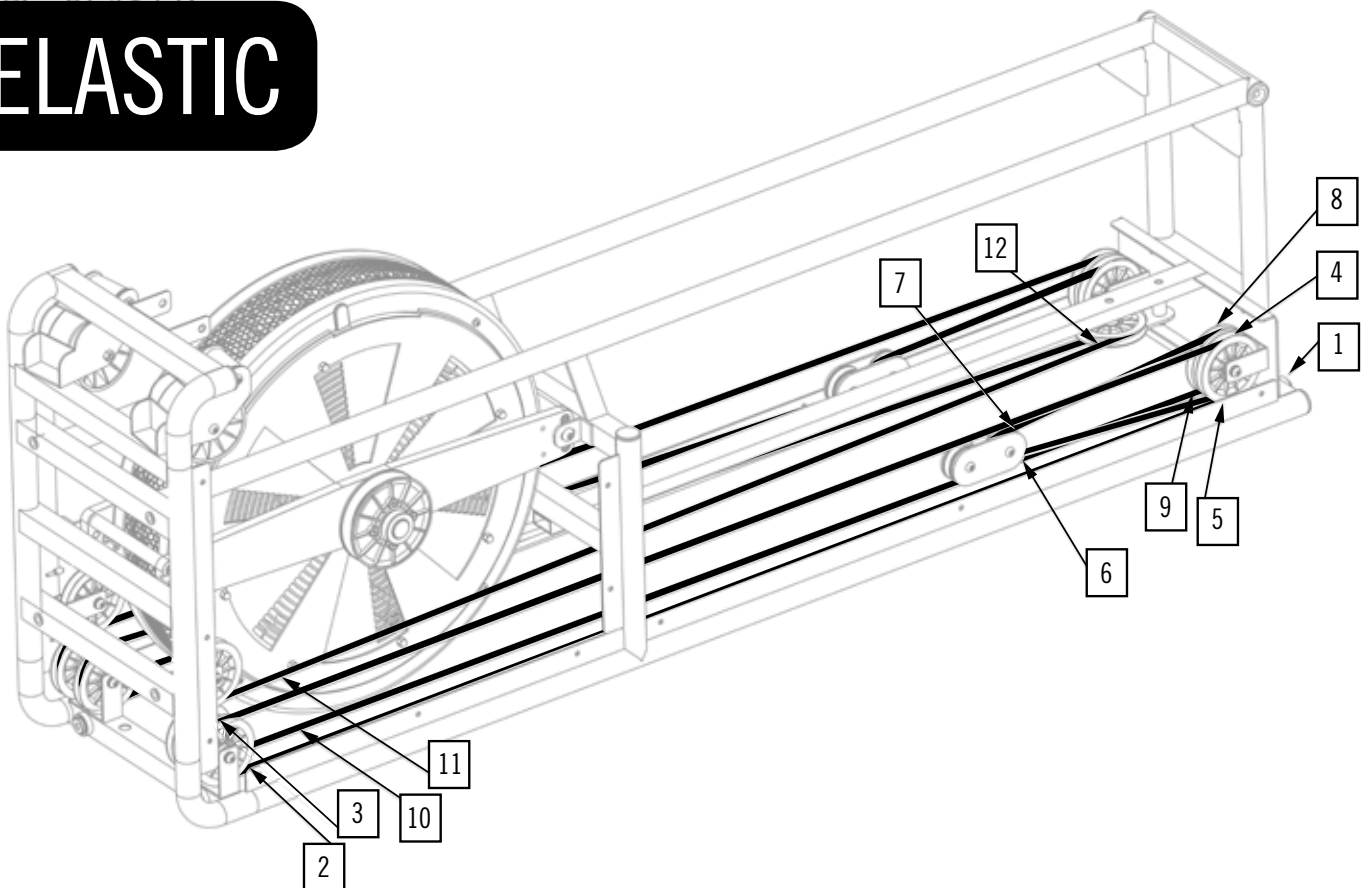

ROPE END

IMPORTANT Rope Length Customization

As your Compact Ergometer [KPC] is shorter than the standard Kayak Ergometer version, it is important that the rope length is customized for each individual paddler.

You may therefore need to experiment [lengthen or shorten] the rope length within the paddle shaft to suit your body type and in order to maintain the correct functionality and positive “catch” of this Ergometer.

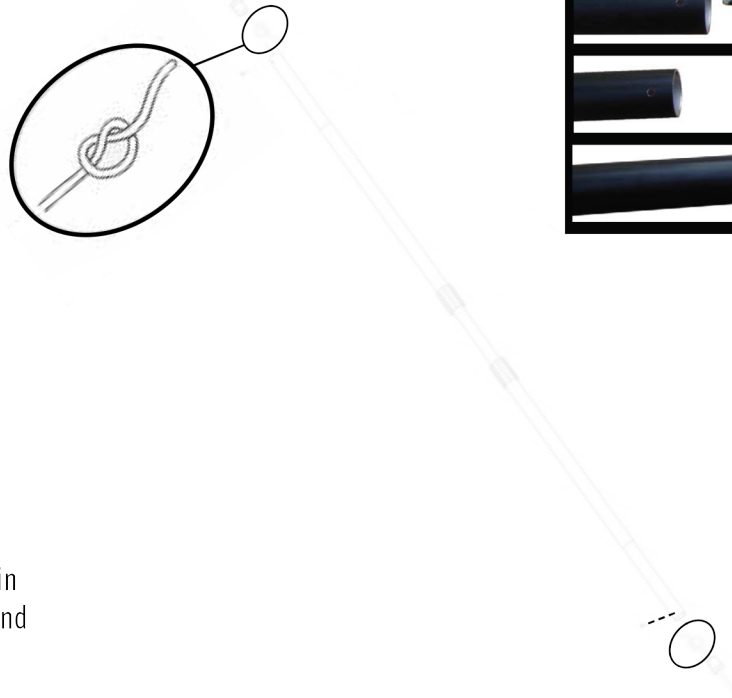

CONTACT US

WWW.KAYAKPRO.COM | +1 914 310 5899 | SALES@KAYAKPRO.COM

KayakPro USA LLC
6538 Collins Ave Suite 306
Miami Beach, FL 33141



OFFICIAL SUPPLIER OF ERGOMETERS
TO THE OLYMPIC GAMES

SUPPLIER OF ERGOMETERS TO NASA
LYNDON B. JOHNSON SPACE CENTER, HOUSTON, TEXAS