

10

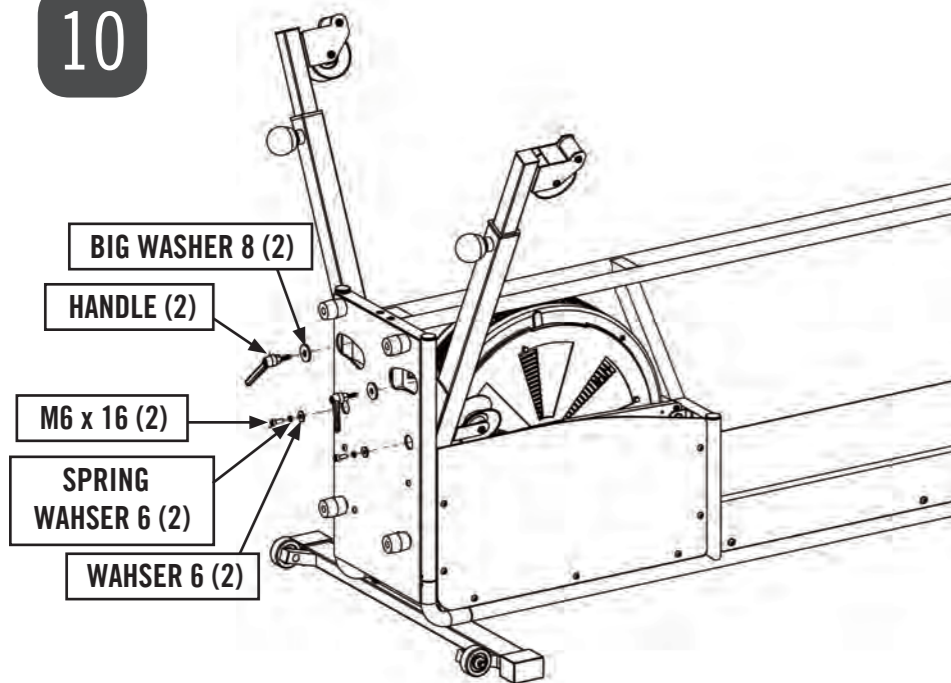

11

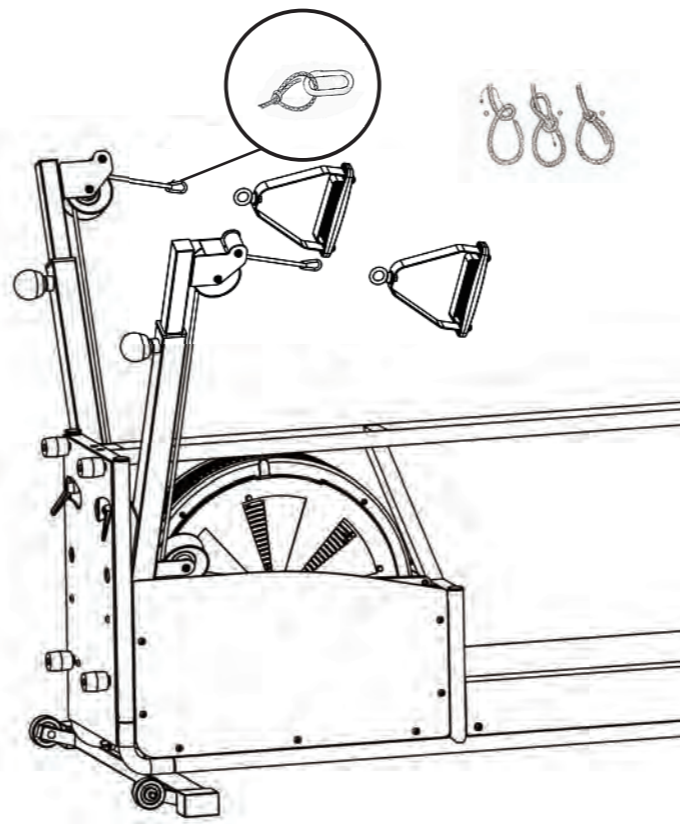

12

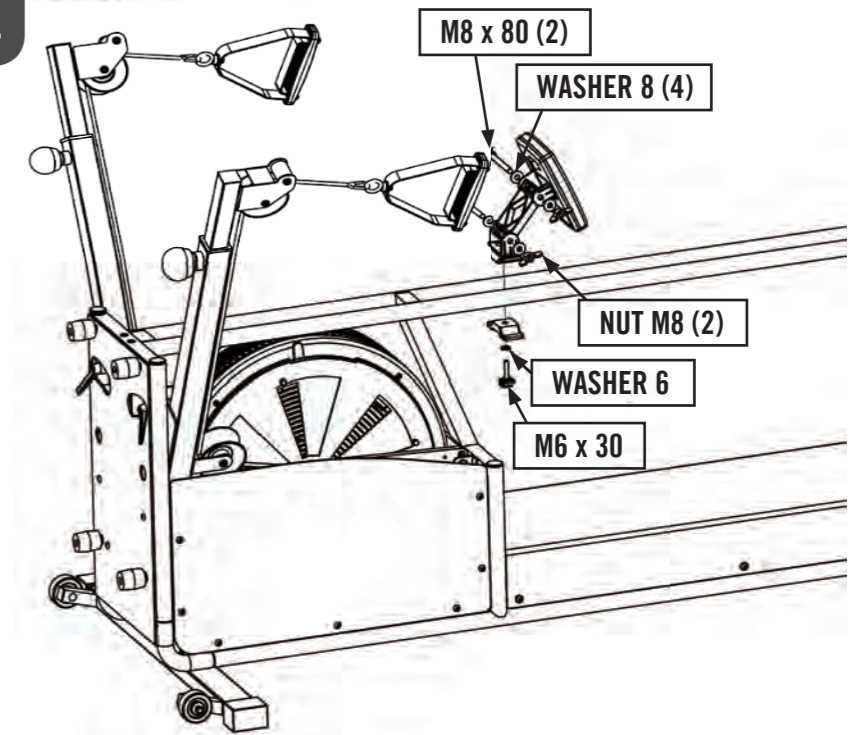

13

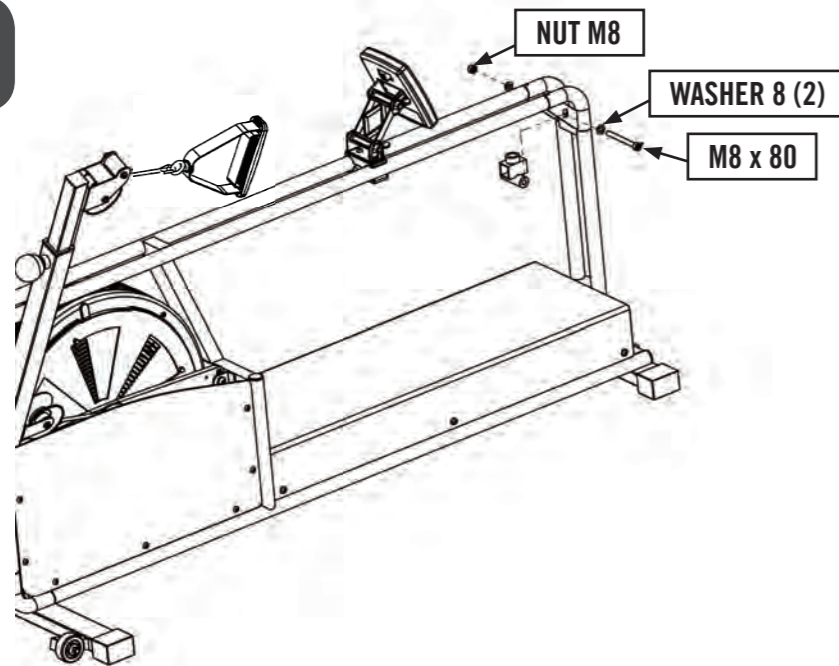

14

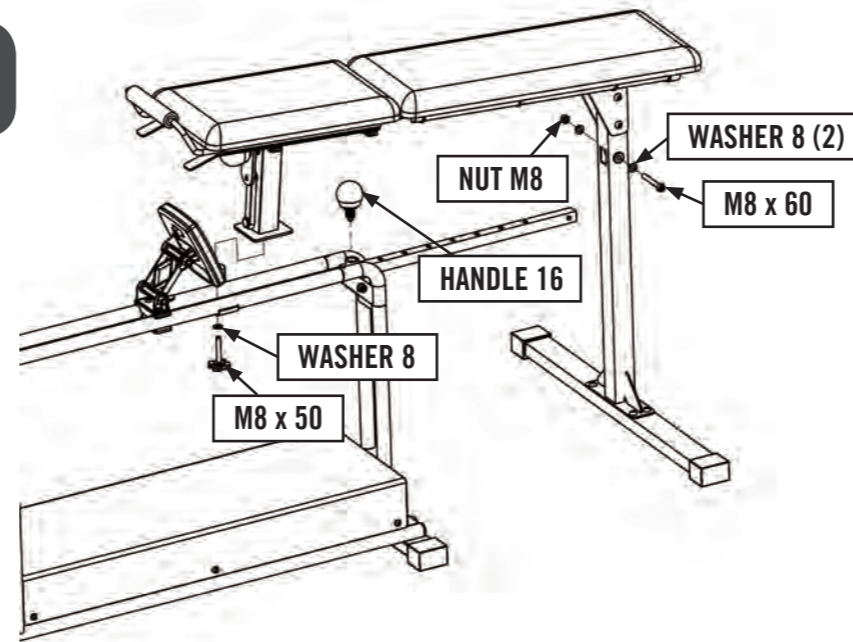

15

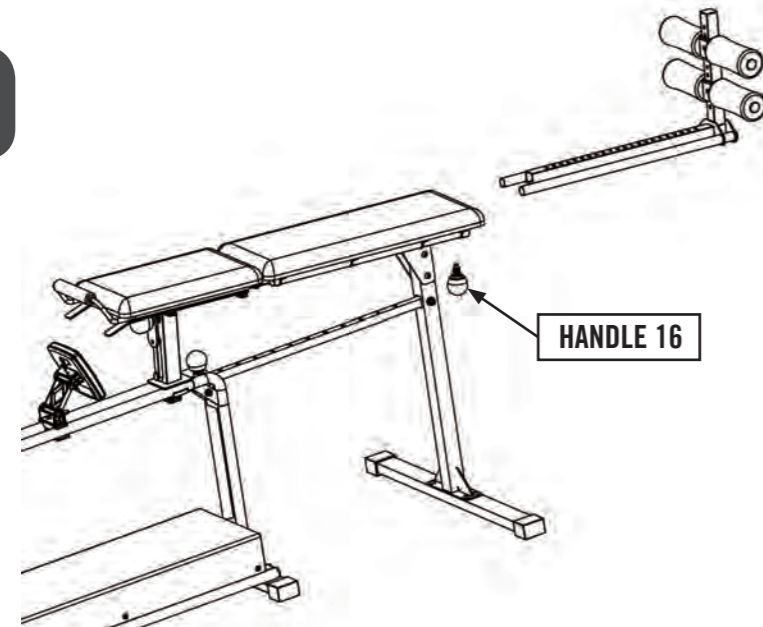

## SAFETY PRECAUTIONS

### SAFE OPERATION AND USE

**SERIOUS INJURY CAN OCCUR IF THE FOLLOWING PRECAUTIONS ARE NOT OBSERVED.**

1. Always consult your physician prior to undertaking any exercise regimen.
2. Keep head, limbs, fingers, and hair clear of all moving parts and flywheel cage.
 

**PLEASE NOTE** For the SwimFast Ergometer, working area is:

<b>TOTAL WIDTH</b>	3.2 m (126")
<b>TOTAL LENGTH</b>	1.6 m (63")
3. Inspect machine prior to use. Do not use the machine if it appears damaged or inoperable.
4. Contact manufacturer if machine is broken or jammed.
5. Use machine only as intended.
6. Do not modify the machine.
7. Children must not be allowed near this machine.
8. Teenagers must be supervised in the use of this machine.
9. By using the SwimFast Ergometer the user accepts all and full responsibility for self.

# KAYAKPRO

#### CONTACT US

WWW.KAYAKPRO.COM  
+1 914 310 5899  
SALES@KAYAKPRO.COM

KayakPro USA LLC  
6538 Collins Ave Suite 306  
Miami Beach, FL 33141